

683-52 REV2 RS-485 OEM Proximity Reader

Shortform Data Sheet

Specifications

Power requirements: 5.0-13.6V dc. Current consumption is 75 mA typical

RF Frequency: 125 kHz.

40 bit read only transponders supported: EM4001 family, TEMIC e5550 and equivalent devices.

Output formats supported: RS-485

Typical reading range with supply voltage in range 5.5V-13.6V: keyring tag 30-40mm, ISO card with 70mm.

3 LEDs (RED, YELLOW, GREEN), controlled by network host.

2 Open Collector Transistor Outputs, controlled by network host.

Specifications: $V_{DSmax} = 60V$, $I_{Dmax} = 300mA$, $P_{tot, 25^{\circ}C} = 830mW$

2 Active-low Inputs, sensed by network host.

Specifications: Internal 10K pull-up to +5V

Sounder emits at 2.4 kHz, controlled by network host.

Operating temperature range: $-20^{\circ}C$ - $+60^{\circ}C$.

10 way cable: 0,9m long

Weight: 90 grams.

Dimensions: reader 89 x 45 x 16 mm, optional spacer plate 89 x 45 x 7 mm

Physical Dimensions and Mounting Details

If the spacer plate is used the reader cable may be brought out of one of four exit points on the spacer: top, bottom, left or right. This enables the cable to be run on the surface of the wall. If no spacer plate is used a minimum hole size of 6.5mm must be drilled in the wall at the cable exit position as shown above to allow the cable to exit perpendicular to the reader.

The optional spacer plate may also be used when mounting the reader on a metal surface to reduce the negative effects of metal on the read range.

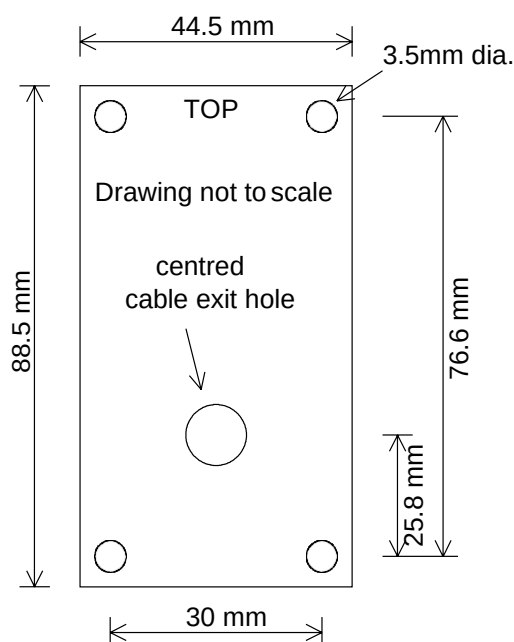

Power Connections

The reader has an internal low dropout 5V regulator and so for maximum performance the input voltage must be smooth DC between 5.5V and 13.6V. The reading distance is unchanged for input voltages between 5.5V and 13.6V. For input voltages below 5.5V the read range drops off by about 20%. If 5V is supplied to the reader this should be noise-free to achieve maximum possible read ranges.

Connections

The table below details the function of each wire:

Colour	Name	Function
GREY	PROGRAM	If held low at startup, Address Programming will commence. See section on Address Programming.
WHITE	OUTPUT 1	Open Collector Output, controlled by a the host
BROWN	OUTPUT 2	Open Collector Output, controlled by a the host
GREEN	INPUT 1	Active low, passively pulled to +5V.
YELLOW	INPUT 2	Active low, passively pulled to +5V.
ORANGE	RS-485 +	RS-485 + line
BLUE	RS-485 -	RS-485 - line
PURPLE	TERMINATE	To terminate the network, link this to RS-485 + (ORANGE) See RS-485 Connections for more information.
RED	+VDC	Connect +5V - +13.6V from power supply.
BLACK	0V	Connect 0V from power supply.

Note: INPUTS 1 & 2 are active low. The input is internally pulled high and may be pulled low by an open collector transistor or driven low by the output of a 5V CMOS or TTL gate.

RS-485 Connections

An RS-485 network is typically an end-to-end bus, with a 120 Ω terminating resistor on each end device, connected between the RS-485 + and the RS485 - lines. One device on this bus (typically the host or controller device) must bias the RS-485 + to the positive rail voltage, and the RS-485 - to the negative rail voltage, using 560 Ω resistors.

Additional devices are then connected to this bus.

The 683-52 provides the facility to terminate a line (ie. be the last device on the bus), but does not provide bias resistors. This must be done on a different device on the network.

To terminate the line, the TERMINATE wire (PURPLE) must be connected to the RS-485 + wire (ORANGE).

The 683-52 allows 5ms for the host device to turn it's RS-485 drivers around and prepare for a reply before it starts transmitting the reply packet.

Grounding Considerations

Grounding an RS-485 network needs to be done properly to avoid ground loops and different potentials between power-supplies.

Ideally, all power-supplies used for devices need to be of a floating variety, where a transformer isolates the ground from the mains supply. The RS-485 lines should then be accompanied by a ground wire, which links all devices to the same reference point.

Alternatively, if the power-supplies are grounded, the ground component of the RS-485 should be left out.

If a combination of these options is used, ground loops may result, which may cause damage to the RS-485 ICs when transient noise is introduced.