

680-52 Rev 3 Proximity Reader Module

Data Sheet

The 680-52 proximity reader module is a fully encapsulated device that will read the code from an RFID transponder and output the code in one of many user selectable formats. The module contains all the detection circuitry required to implement a proximity reader including an internal coil antenna. A larger external reader coil may be connected if greater reading range is required.

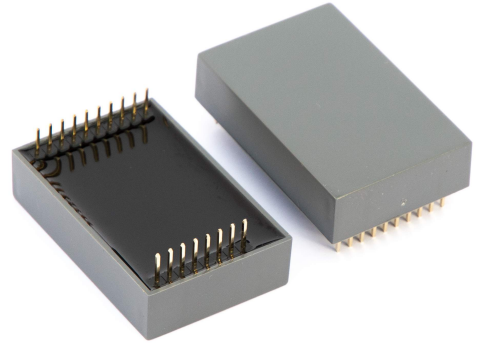

Specifications

- Power requirements: either regulated 5V dc or unregulated 5.5V – 12V dc. Current consumption: 65mA (typ); 95mA (max. all conditions)
- RF Frequency: 125 kHz
- 40 bit read only transponders supported: EM4001 family, TEMIC e5550 and equivalent devices
- Output formats supported: Wiegand (42 bit, 34 bit, and 26 bit), Mag stripe emulation, Clock/Data, RS232-TTL (9600,n,8,2) 5V TTL levels, Crosspoint card decoding
- Continuous output with tag in field or single transmission
- Typical read range with internal coil: 90 mm for ISO cards, 60 mm for keyring tag
- External coil connection for remote reading or extended read range
- Connection for piezo beeper: 4 kHz PWM; 50 ms beep on card read
- Operating temperature range: -10 °C to +50 °
- Weight: ~20 grams

Pinout Description and Dimensions

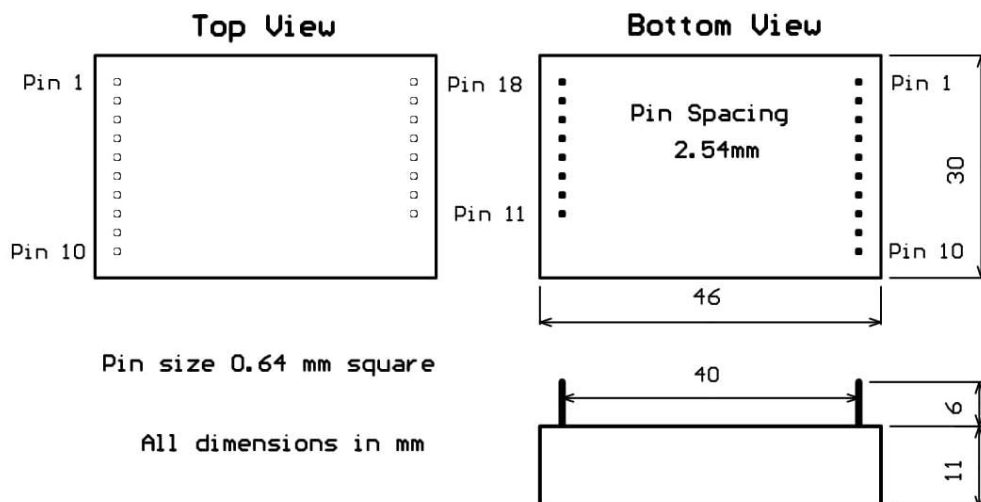

Pin #	Pin Name	Function
1	DETECT	Output: drives LOW for duration of output transmission ¹
2	CLOCK/DATA0	Output: outputs tag code in selected format ¹
3	DATA/DATA1	Output: outputs tag code in selected format ¹
4	CONTINUOUS	Input: connect to 0V for continuous transmission mode. Connect to +5V or leave floating for single transmission mode ²
5	INVERT	Input: connect to 0V to invert the output on pins 1,2 and 3 ^{2,3}
6	SELECT1	Input: connect to 0V or leave floating to select different output formats ²
7	SELECT2	
8	SELECT3	
9	SELECT4	
10	RESERVED	Leave disconnected
11	COIL A	Coil driver: connect to COIL LINK for internal coil or connect to external coil ⁴
12	COIL LINK	Link to COIL A to for internal coil or leave disconnected for external coil
13	COIL B	External coil connection
14	RAW DATA	Output: raw data stream detected from tag
15	BEEPER	Output: open collector PWM drive for external piezo beeper
16	+5V	Power: operation of module from 5V
17	+12V	Power: operation of module from 5.5V to 12V
18	0V	Power: connect to 0V of power supply

[1] 5V logic, $Z_{out} \approx 1.2k$

[2] Inputs are pulled HIGH internally, may be left floating

[3] Current consumption increases +15mA for inverted outputs

[4] Can use series resistor of value $4.7 \Omega - 10 \Omega$ (100mW) to reduce module current, trades off read range - (same arrangement can also be used with external coil)

Output Mode Selection

The module has four selection pins (SELECT1 ... SELECT4). These pins are internally pulled HIGH in the module. To select the different output formats the SELECT pins may be tied to 0V (indicated as 0) or left unconnected (indicated as 1) according to the following table:

SELECT4	SELECT3	SELECT2	SELECT1	Output format
0	0	0	0	Inhibit – turn off coil
0	0	0	1	RS232-TTL – 24 bit
0	0	1	0	RS232-TTL – 32 bit
0	0	1	1	RS232-TTL – 40 bit
0	1	0	0	<i>Unused</i>
0	1	0	1	<i>Unused</i>
0	1	1	0	Fast Mag Stripe – 32 bit
0	1	1	1	Crosspoint
1	0	0	0	Fast Mag Stripe – 40 bit
1	0	0	1	Mag Stripe – 24 bit
1	0	1	0	Mag Stripe – 32 bit
1	0	1	1	Mag Stripe – 40 bit
1	1	0	0	Basic Clock/Data
1	1	0	1	Wiegand 26 bit
1	1	1	0	Wiegand 34 bit
1	1	1	1	Wiegand 42 bit

Power Connections

Power can be supplied to the module in two ways:

1. For voltages +5.5 to +12 volts connect power to pin 17 (+V) and pin 18 (0V); **do not exceed +12.6V**
2. Alternatively the internal regulator may be bypassed. Regulated +5V may be connected to pin 16 (+5V) and pin 18 (0V); **do not exceed +5.5V**

External Beeper Connection

The module pin 15 (BEEPER) is an open collector output. It outputs a frequency of 4kHz for 50ms when a tag is read. Shown are two typical circuits that can be used to connect a beeper:

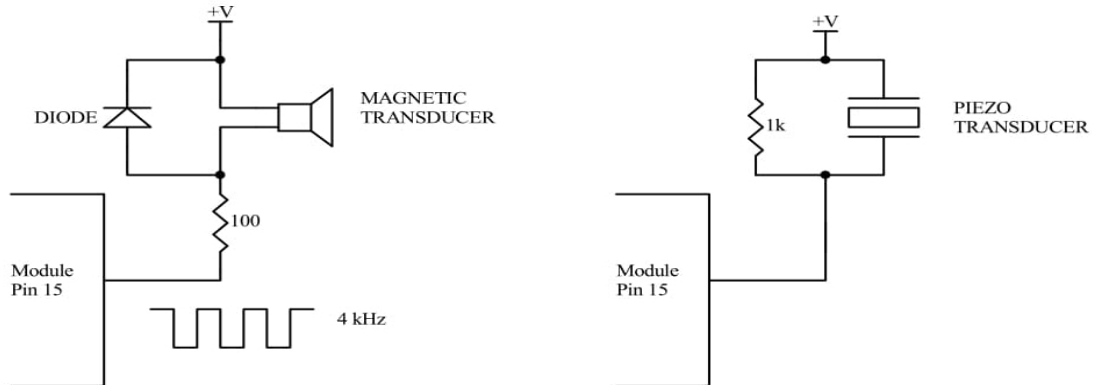

Coil Connection

The module has an internal coil which may be suitable for many applications. The internal coil is selected by connecting pin 11 (COIL A) to pin 12 (COIL LINK). A resistor in the range of 4.7 to 10 ohms (100mW) may be used in series with the link to reduce the module current (read range may decrease).

If an external coil is required to obtain a greater reading range, a coil of 486uH to 508uH must be connected between pin 11 (COIL A) and pin 13 (COIL B), with COIL LINK unconnected (internal coil not used). A resistor in the range of 4.7 to 10 ohms (100mW) may be used in series with the external coil to reduce the module current (read range may decrease).

Inverted Outputs

The polarity of DETECT (pin 1), CLOCK/DATA0 (pin 2) and DATA/DATA1 (pin3) may be inverted by connecting pin 5 (INVERT) to 0V. (Note. In this mode module current increases by +15mA).

In all modes the idle level of the output data pins (1, 2, and 3) is HIGH. This is acceptable when connecting the module directly to the receiving equipment over a short length. However when a long cable exists between the module and the receiving equipment it is desirable to include an open collector transistor stage between the module and the long cable as shown below:

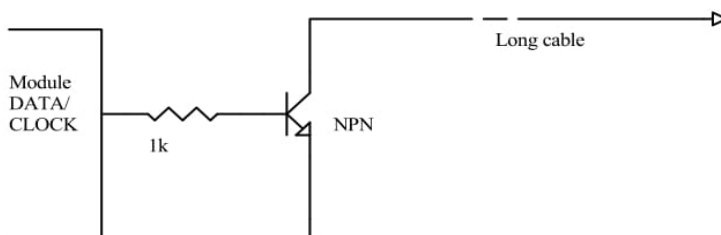

To ensure the idle state of the transistor is OFF the idle level from the module output data pins must be LOW, to achieve this connect INVERT to 0V.

The INVERT pin has no affect on the RS232 output modes.

Continuous mode

When pin 4 (CONTINUOUS) is connected to 0V the reader repeatedly transmits the tag code in the selected format every 100ms.

In SINGLE transmission mode (pin 4 floating) the reader transmits the tag code once only; the tag must be removed from the field for at least 1 second before the same tag can be re-read and the code re-transmitted.

RS232-TTL Output modes

The RS232-TTL output from the module is on DATA (pin 3). This output is suitable to connect directly to the UART of a microprocessor. The idle level is HIGH. The baud rate is 9600; data format is 8 bits, no parity and 2 stop bits.

To achieve true RS232 levels and polarity the module output should be connected to an EIA-232 DRIVER IC (e.g. MAX232).

The tag code is output in the following structure:

STX(02h)	DATA(ASCII)	CR(0Dh)	LF(0Ah)	ETX(03h)
----------	-------------	---------	---------	----------

The data bytes vary according to the number of bits being output:

40 bit mode

DATA = 10 ASCII characters representing the 40 bit hexadecimal number of the tag code, e.g. '0410B2F12A' (30 34 31 30 42 32 46 31 32 41 hex)

32 bit mode

DATA = 10 ASCII characters representing the least significant 32 bits of the tag code converted to decimal, e.g. '0280162602' (30 32 38 30 31 36 32 36 30 32 hex)

24 bit mode

DATA = 8 ASCII characters representing the least significant 24 bits of the tag code converted to decimal, e.g. '11727146' (31 31 37 32 37 31 34 36 hex)

Wiegand Output Modes

In this mode the tag code is pulsed out on DATA0 (pin 2) and DATA1 (pin 3). Both are normally HIGH. When a tag is presented to the reader, one of 26, 34, or 42 bits are transmitted in the following way:

A binary 1 is represented by a 100us pulse LOW on DATA1. A binary 0 is represented by a 100us pulse LOW on DATA0. There is a 2ms inter bit delay.

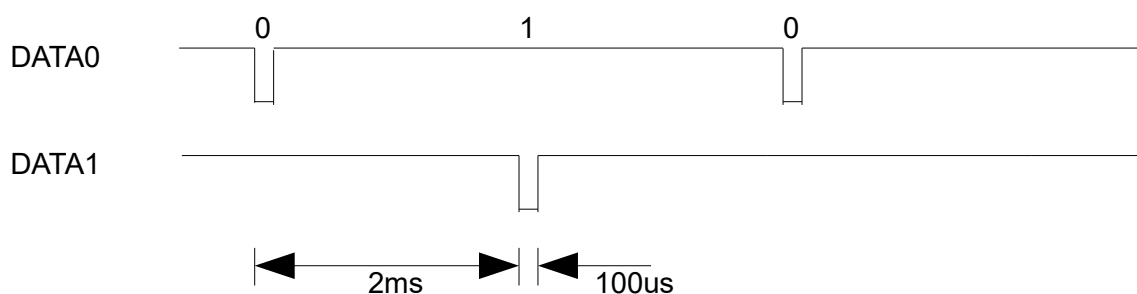

42 bit mode

42 pulses are transmitted:

- the first bit is the even parity of tag bits 1-20
- all 40 bits of the tag code (MSB first)
- the last bit is the odd parity of the tag bits 21-40

34 bit mode

34 pulses are transmitted:

- the first bit is the even parity of the tag bits 9-24
- the least significant 32 bits of the tag code (MSB first)
- the last bit is the odd parity of the tag bits 25-40

26 bit mode

26 pulses are transmitted:

- the first bit is the even parity of the tag bits 17-28
- the least significant 24 bits of the tag code (MSB first)
- the last bit is the odd parity of the tag bits 29-40

Clock/Data Mode

In this mode all 40 bits of the tag code are clocked out with an eight bit header and an eight bit checksum

HEADER (11111110)	DATA (40 bits)	CHECKSUM
-------------------	----------------	----------

The HEADER is hex FE. The DATA consists of 40 tag code bits sent MSB first. The checksum is the byte addition of the 5 bytes of DATA bits, e.g. tag code 0410B2F12Ah has the checksum 04h+10h+B2h+F1h+2Ah=E1h

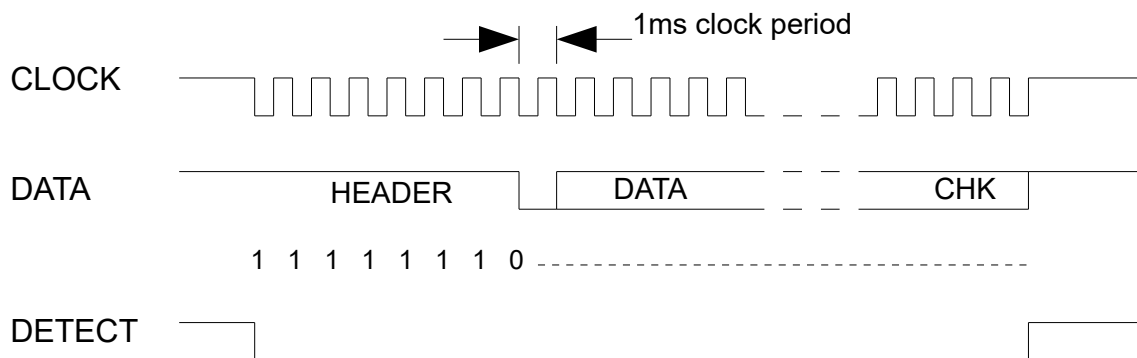

Data is set up on the falling edge of the clock and is stable on the rising edge of the clock.

Mag Stripe Modes

In this mode the decimal tag number is clocked out on CLOCK (pin 2) and DATA (pin 3) at 100 characters per second. The format is standard as found on Track 2 of a magnetic card:

10 leading 0's	SS	DATA	ES	LRC	5 trailing 0's
----------------	----	------	----	-----	----------------

SS = start sentinel (B hex)

ES = end sentinel (F hex)

LRC = longitudinal redundancy check

DATA varies according to the number of bits selected:

40 bit mode

DATA = 13 decimal digits with leading zeros. The most significant decimal digit is transmitted first.

32 bit mode

DATA = 10 decimal digits with leading zeros. The most significant decimal digit is transmitted first.

24 bit mode

DATA = 8 decimal digits with leading zeros. The most significant decimal digit is transmitted first.

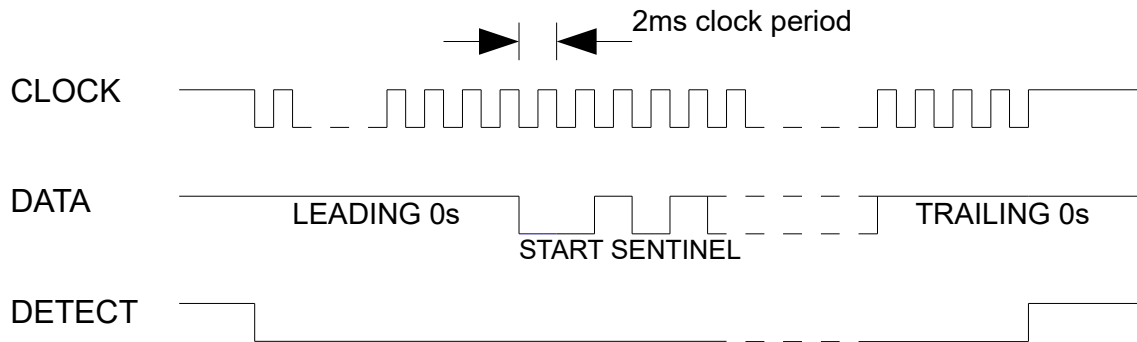

Each character is 5 bits long. The first four bits are the hex digit (0-F) least significant bit first. The fifth bit is the odd parity bit. A 0 is represented by a HIGH level on the DATA pin and a 1 is represented by a LOW level on the DATA pin. Data is set up on the falling edge of the clock and is stable on the rising edge of the clock. The DETECT output goes LOW for the duration of the transmission simulating the CARD DETECT from a mag. card reader.

Fast 40 bit mode

This mode differs from the standard 40 bit mag stripe mode in the following ways:

- DATA = 14 decimal digits with leading zeros
- the clock period is 200us
- ends with 10 trailing zeros

All other aspects of this format are the same as the other mag stripe formats.

Fast 32 bit mode

This mode differs from the standard 32 bit mag stripe mode in the following ways:

- the clock period is 200us
- ends with 10 trailing zeros

All other aspects of this format are the same as the other mag stripe formats.

Crosspoint mode

In this mode the reader assumes the card is encoded as per the Crosspoint bit scrambling algorithm. The unscrambled decimal tag number is clocked out on CLOCK (pin 3) and DATA (pin 2) at 1000 characters per second. The clock is 200us. The format is standard as found on Track 2 of a magnetic card:

10 leading zeros	SS	DATA	ES	LRC	10 trailing 0's
------------------	----	------	----	-----	-----------------

SS = start sentinel (B hex)

ES = end sentinel (F hex)

LRC = longitudinal redundancy check

DATA consists of 9 decimal digits with leading zeros. The most significant decimal digit is transmitted first.